

NOTES:
 1. 5/8" ϕ MOUNTING HARDWARE IS RECOMMENDED FOR 6X6, 8X8 AND 12X12 BASEPLATE MODELS. L-BOLT-625, STUD-ANCHOR-625



PEDESTALPRO.COM
 1-800-660-3072

UNLESS OTHERWISE SPECIFIED:

DIMENSIONS ARE IN INCHES
 TOLERANCES:
 FRACTIONAL $\pm 1/32$
 ANGULAR: $\pm 2^\circ$
 TWO PLACE DECIMAL ± 0.010
 THREE PLACE DECIMAL ± 0.005

INTERPRET GEOMETRIC
 TOLERANCING PER:
 ASME Y14.5 -2009

| UNLESS OTHERWISE SPECIFIED: | NAME | DATE |
|-----------------------------|------|------|
| DRAWN | | |
| CHECKED | | |

PROPRIETARY AND CONFIDENTIAL
 THE INFORMATION CONTAINED IN THIS DRAWING IS THE SOLE PROPERTY OF PEDESTALPRO LLC. ANY REPRODUCTION IN PART OR AS A WHOLE WITHOUT THE WRITTEN PERMISSION OF PEDESTALPRO LLC IS PROHIBITED.

TITLE:
INSTALLATION

Thursday, October 25,
 2018 2:57:46 PM

WEIGHT:

| SIZE | PART NO. | REV |
|----------|-----------|----------|
| A | 36-LP-BLK | A |

NO SCALE SHEET 1 OF 3

| ITEM NO. | PART NUMBER | DESCRIPTION | QTY. |
|----------|---------------|------------------------------------|------|
| 1 | 36-LP-BLK | 3x3 STEEL TUBE | 1 |
| 2 | COVER PLATE 6 | 6" STANDARD COVER PLATE | 1 |
| 3 | BASE PLATE 6 | 6" STANDARD BASE PLATE | 1 |
| 4 | CAP PLATE 3 | 3" STANDARD CAP PLATE | 1 |
| 5 | -- | 1/4-20 X .50 ZINC PL CARRIAGE BOLT | 4 |
| 6 | -- | 1/4-20 ZINC PL HEX NUT | 4 |

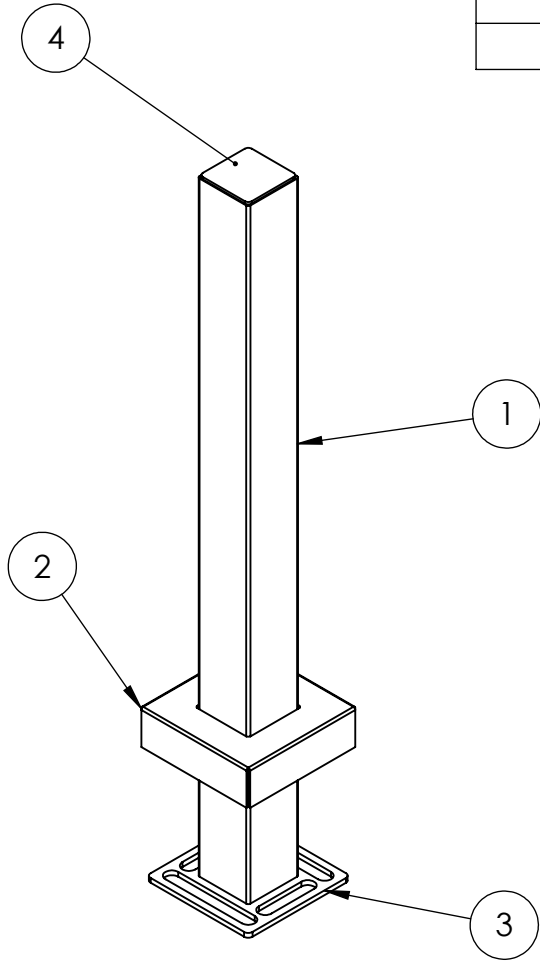

NOTES:

1. BUTT WELDED SECTIONS ARE NOT ALLOWED, EACH SECTION OF TUBE MUST BE FROM CONTINUOUS STOCK.
2. ALL WELDS ARE TO BE CONTINUOUS FILLET WELDS UNLESS NOTED OTHERWISE.
3. SEE STANDARD PREPARATION AND COATING INSTRUCTIONS FOR COATING PROCEDURE AND COLOR.
4. FASTENERS ARE TO BE BAGGED AND SHIPPED WITH PEDESTAL.
5. SEE STANDARD PACKAGING INSTRUCTIONS FOR PACKAGING PROCEDURE.



PEDESTALPRO.COM
1-800-660-3072

UNLESS OTHERWISE SPECIFIED:

DIMENSIONS ARE IN INCHES
TOLERANCES:
FRACTIONAL $\pm 1/32$
ANGULAR: $\pm 2^\circ$
TWO PLACE DECIMAL ± 0.010
THREE PLACE DECIMAL ± 0.005

INTERPRET GEOMETRIC
TOLERANCING PER:
ASME Y14.5 -2009

| NAME | DATE |
|---------|------|
| DRAWN | |
| CHECKED | |

PROPRIETARY AND CONFIDENTIAL

THE INFORMATION CONTAINED IN THIS DRAWING IS THE SOLE PROPERTY OF PEDESTALPRO LLC. ANY REPRODUCTION IN PART OR AS A WHOLE WITHOUT THE WRITTEN PERMISSION OF PEDESTALPRO LLC IS PROHIBITED.

TITLE:
ASSEMBLY

Thursday, October 25,
2018 2:57:46 PM

WEIGHT:

| | |
|----------|-----------|
| SIZE | PART NO. |
| A | 36-LP-BLK |

| |
|----------|
| REV |
| A |

NO SCALE

SHEET 2 OF 3